

UDU 11 T P/S MN

Liquid soap dispenser with open refill system

Art.-No. 1424313



OPHARDT HYGIENE-TECHNIK GmbH + Co. KG
Lindenau 27 | 47611 Issum | Germany
Tel.: +49 (0) 28 35 18-10 | Fax +49 (0) 28 35 18-77
planer@ophardt.com | www.ophardt.com

UDU 11 X10 Touchless

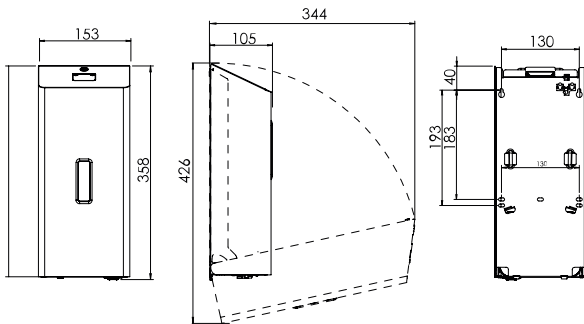

Maße in mm - Dimensions in mm



References

airports, train stations, schools, kindergardens, hotels, restaurants, commercial kitchen, food processing areas, prisons, exhibitions, conference centres, shopping centres, fitness and sports centres, industry, laboratories, administration facilities

Usage examples

washrooms, toilets, baths, nursing and examination rooms, kitchens, production facilities, entrance area

Technical data

Dispenser type:	refillable dispenser
Housing:	Stainless steel, matte black powder coated (RAL 9005)
Filling volume (ml):	1200 ml
Dosing pump:	long-life plastic soap pump
Dosage quantity:	0.4 / 0.8 / 1.2 ml/stroke
Filling good:	Liquid soaps, Disinfectant
Operating type:	Touchless
Power type:	Battery
with/without viewing window:	Clear
with drip tray:	No
Lock:	SanTRAL vandalism-proof lock, plastic
Batteries:	4x Alkaline D batteries, 1.5 V, exchangeable, non-rechargeable
Recommended Batteries:	DURACELL ULTRA POWER D, VARTA 4020 (INDUSTRIAL), VARTA 4120, VARTA 4720
Mounting:	Wall mounting with 4 screws and wall plugs, recommended distance to the countertop min. 20 cm
Cleaning:	manual wipe disinfection, not dishwashersafe, not autoclavable
Warranty:	5 years
Net weight:	2.628 kg
Dimensions (W x H x D) in mm:	153x358x105
Hinweis:	Before using new products, please always check the compatibility of the product and the dispensing system to ensure proper functionality.

Compatible accessories

Stand for UDU 11 T
Hygiene stand for effective hand disinfection Art.-No. 1424790

Please see other accessories in our Online Product Catalogue.